

- 1
- 2
- 3
- 4
- 5
- 6
- 7
- 8
- 9
- 10
- 11
- 12
- 13
- 14
- 15
- 16
- 17
- 18

MAIN SPECIFICATIONS

- 1 Aluminium
- 2 Epoxy resin coating
Black, RAL 9005, textured finish **SW**
- 3 Sleeve bearing
Plastic (PTFE)
- 4 Socket cap screws DIN 912
Stainless Steel AISI 304
- 5 Hex nuts DIN 985
Stainless Steel AISI 304
- 6 Self-locking via polyamide ring

FEATURES AND APPLICATIONS

Two-way linear actuator connectors GN 133.2 are based on two-way connector clamps. The additionally provided mounting holes are used to connect to the drive key of a linear actuator. Bore with the designation **G** are equipped with sleeve bearings. With the screw locations z1 / z2, the play of the guide bores d1 / d2 can be adjusted or the linear actuator connectors can be clamped after adjustment. For quick clamping without tools, the socket cap screws can be replaced by the adjustable hand levers GN 911 (see page).

ACCESSORY

Adjustable Hand Levers GN 911 (see page).

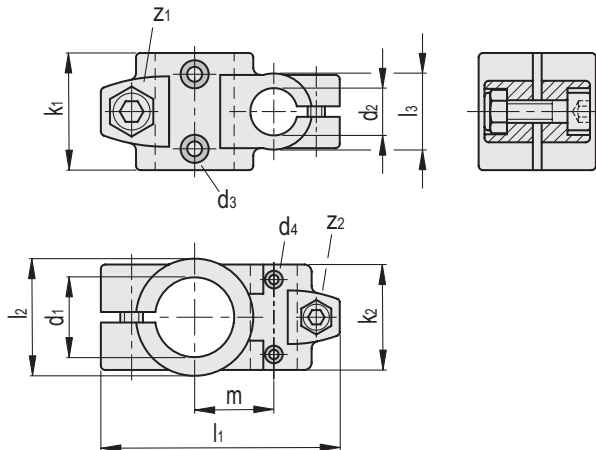
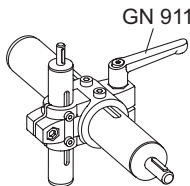

GN 133.2-B

Code	Description	d1 - d2 without sleeve bearing	d3	d4	k1	k2	l1	l2	l3	m	z1	z2	z1 Clamping kit	z2 Clamping kit	
GN.43661	GN 133.2-B30-B18-2-SW	B 30 - B 18	M 4	M 3	40	36	81.5	40	26	27	M8-25	M6-20	GN 911-63 / GN 911-78	GN 911-45 / GN 911-63	133
GN.43663	GN 133.2-B50-B30-2-SW	B 50 - B 30	M 6	M 4	65	59	122	65	40	45	M10-50	M8-25	GN 911-78 / GN 911-92	GN 911-63 / GN 911-78	450

GN-133.2-G

Code	Description	d1 - d2 with sleeve bearing	d3	d4	k1	k2	l1	l2	l3	m	z1	z2	z1 Clamping kit	z2 Clamping kit	
GN.43665	GN 133.2-G30-G18-2-SW	G 30 - G 18	M 4	M 3	40	36	81.5	40	26	27	M8-25	M6-20	GN 911-63 / GN 911-78	GN 911-45 / GN 911-63	133
GN.43667	GN 133.2-G50-G30-2-SW	G 50 - G 30	M 6	M 4	65	59	122	65	40	45	M10-50	M8-25	GN 911-78 / GN 911-92	GN 911-63 / GN 911-78	450

Tube connectors